

Perma Flux™ V8 HE pH+ Module

Tubular Membranes Reinvented

DESCRIPTION AND USE

- PermaFlux™ is a state-of-the-art **pressurized membrane** product offering limited hydraulic pressure loss leading to much smaller pumps and energy efficiency up to 90% better than incumbent tubular
- Ultra high **suspended solids** (up to 150,000 mg/L) and **oil and grease** (up to 50,000 mg/L) concentrations
- Minimal **operating costs**
- Fully **back-washable** modules allowing for extended operation between maintenance cleans
- **No aeration** requirements
- **Limited maintenance cleaning** protocols limit downtime and maximizes productivity
- **Ultrafiltration** permeate suitable for re-use in some applications

STANDARD APPLICATIONS

The PermaFlux™ module is best suited for numerous applications including (but not limited to):

- Industrial/Oily Wastewater
- Landfill & Remediation
- Municipal Sludge Thickening
- Pulp & Paper
- Algae Thickening
- Metal Separation
- Food and Beverage Waste & Clarification
- Pharmaceuticals & Chemicals
- Mining
- Anaerobic MBR (liquid/solid separation)

Ultrafiltration quality permeate can be stored and re-used for some non-potable applications (rinsing/washing, cooling towers, boilers, irrigation, etc).

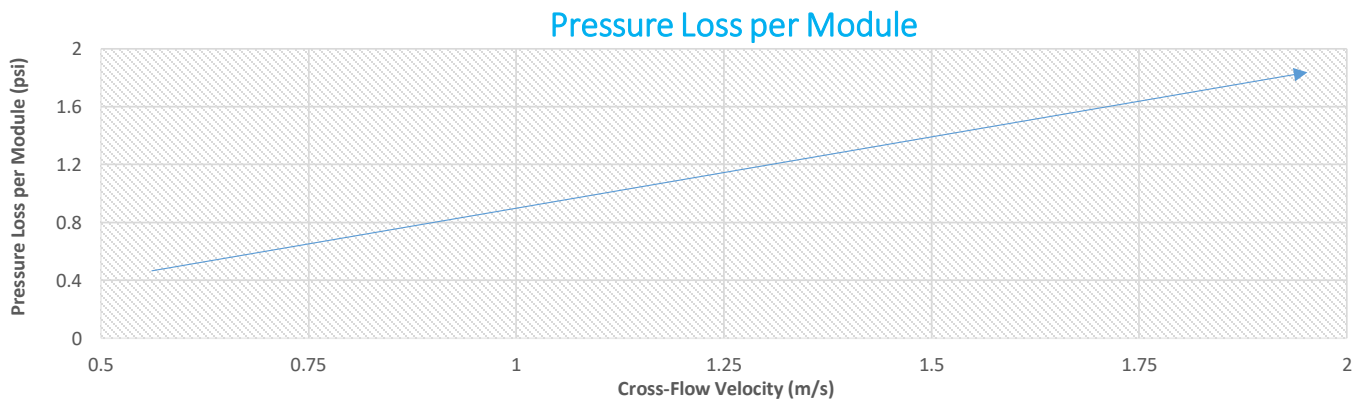

*Graph data based on water at 68 °F (20 °C) and a viscosity up to 10 cP

PermaFlux™ is a trademark of Thetis Environmental that may be registered in one or more countries.

Perma Flux™ V8 HE pH+ Module

Tubular Membranes Reinvented

PRODUCT PROPERTIES	
Model	PermaFlux™ V8 HE pH+
Active Surface Area	10.7 m ² (115 ft ²)
Membrane Configuration	28 filtration filaments in parallel
Membrane Material	PES
Housing Material	PVC/CPVC (application specific)
Flow Path	Outside-in
Membrane Pore Size	0.04 μm
Molecular Weight Cut-Off	100 kDalton

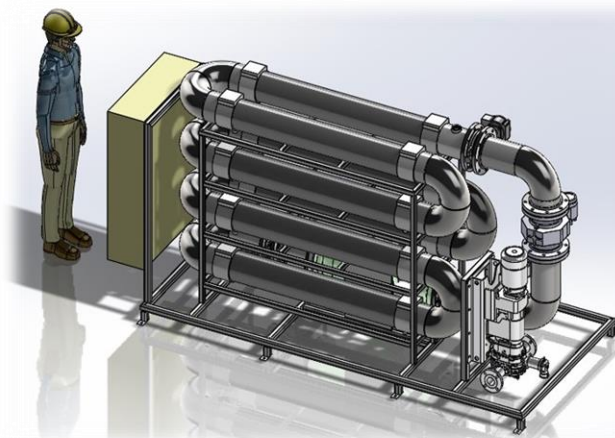

MODULE SPECIFICATIONS	
Length	1,500 mm (60")
Housing Diameter	200 mm (8")
Permeate Connection	Custom coupling with 1" male NPT (optional camlock or hosebarb)
Maximum Preserved Module Shipping Weight	32 kg (70 lb)
Maximum Operating Module Weight	42 kg (92 lb)

OPERATING PARAMETERS	
Trans-Membrane Pressure (TMP) Range	PERMEATION: <138 kPa (20 psig) BACKWASH: <103 kPa (15 psig)
Permeate Flow Range	5.4 - 109 m ³ /day (1 - 20 GPM)
Temperature Range	5 - 55°C (41 - 131°F)
Operating pH Range	5 - 13
Cross Flow Velocity Range*	0.5 - 2 m/s

* The rate the water is traveling within the module

PermaFlux™ is a trademark of Thetis Environmental that may or may not be registered in one or more countries.

MEMBRANE AND SYSTEM PROPERTIES	
-	Patented closed loop batch filtration system reduces maintenance and energy consumption by up to 90% compared to incumbent tubular membrane technologies
-	Expected energy consumption of 0.5 - 3.0 kWh/m³ permeate produced
-	Typical installed power of 0.1 hp/m² membrane (expected use of installed power is <30%)

CLEANING LIMITS	
Maximum Cleaning Temperature	45°C (113°F)
Cleaning pH Range	1.9 - 13 (<35°C); 1.9 - 12.5 (>35°C)
Chemical Concentration	200 - 2,000 ppm